

Contents

ENGLISH	2
Vehicle Details	2
Kit Details	2
Recommended Compressors	3
Compressors Kit Configurations.....	3
Parts View	4
Parts List	5
Foreword	6
Standard Torque Values	6
Pre Installation	7
Drive Pulley Installation	8
Tensioner Installation	8
Mount Bracket Installation	9
Compressor Installation	9
Drive Belts	10
Post Installation	10
Notes	12

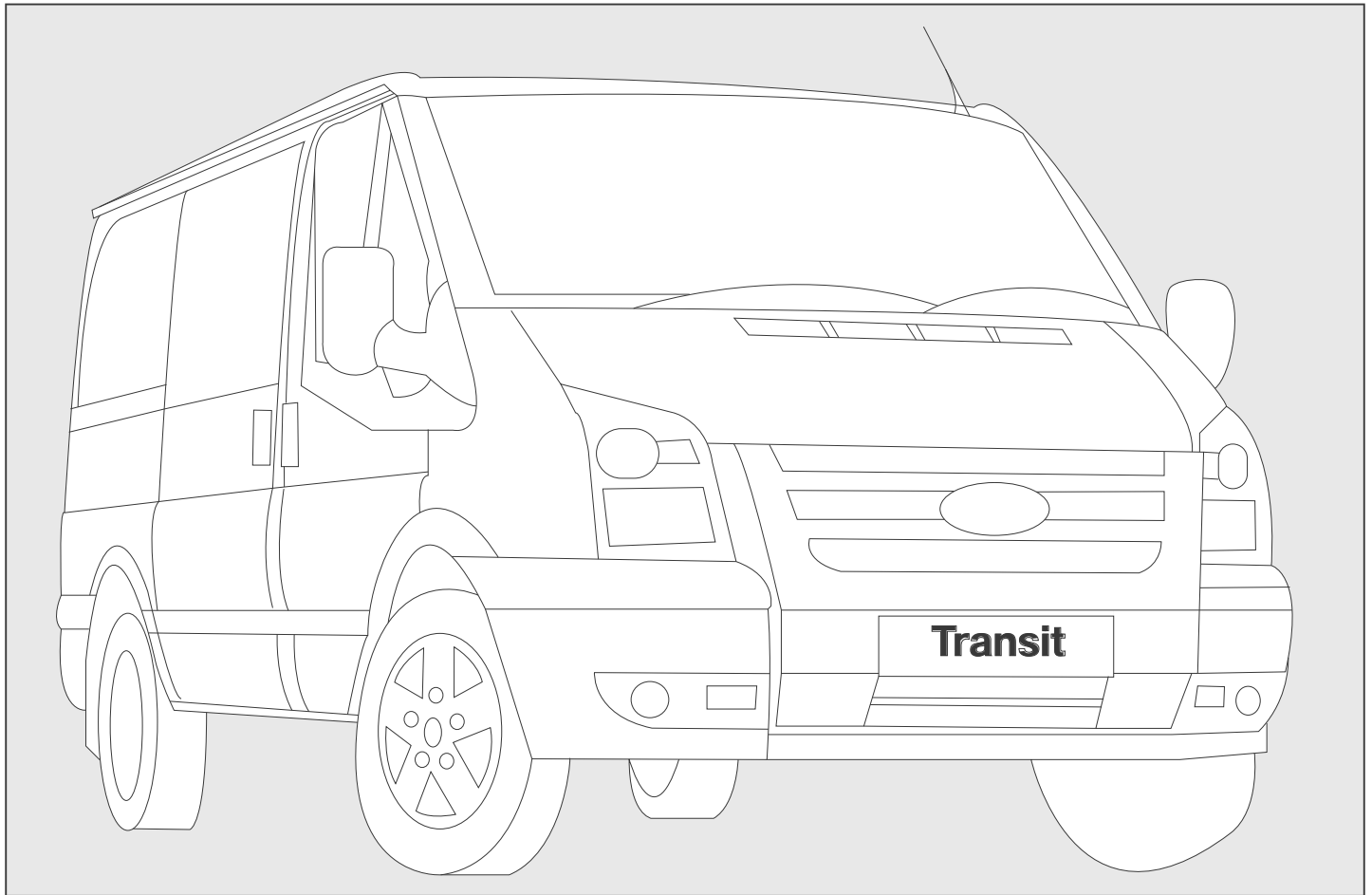

VEHICLE DETAILS

Manufacturer	Ford
Make	Transit RWD
Model	280, 300, 330, 350, 430
Engine CC	2402cc
Engine Details	100, 115, 140 PS
Year	10.2010 >12.2011
Chassis Nos.	N/A
LHD	YES
RHD	YES
PAS	YES
A/C	NO
Voltage	12v

KIT DETAILS

Kit Part No.	0500.6122
Description	Standard Kit
Compressor RPM	3500
Fitting Time	60 Minutes
Suction Fitting	45°
Discharge Fitting	45°
Belt Type	4PK 0975
Belt Part No.	0820.5171

Note:

RECOMMENDED COMPRESSORS

SELTEC	TM-13 HS	TM15-HS	TM16-HS
Comp No	0381.0412	0381.0032	0831.0512
Seltec No.	-	48845322	48846332
Mounting	Ear	Ear	Ear
Rotor	8PV	8PV	8PV
Armature	SL	SL	SL
Diameter	123	123	123
Voltage	12	12	12
Orientation	H	H	H
Fitting	3/4 x 7/8	3/4 x 7/8	3/4 x 7/8
Manifold	Bolt	Bolt	Bolt

QUE	QP13-HD	QP15-HD	QP16-HD
Comp No	0391.0412	0391.0032	0391.0512
Que No.	-	QP15.1340	-
Mounting	Ear	Ear	Ear
Rotor	8PV	8PV	8PV
Armature	SL	SL	SL
Diameter	123	123	123
Voltage	12	12	12
Orientation	H	H	H
Fitting	3/4 x 7/8	3/4 x 7/8	3/4 x 7/8
Manifold	Bolt	Bolt	Bolt

SANDEN	SD5H09	SD5H14	SD5H15
Comp No	-	-	0371.0012
Sanden No.	-	-	4860
Mounting	-	-	Ear
Rotor	-	-	8PV
Armature	-	-	SL
Diameter	-	-	119
Voltage	-	-	12
Orientation	-	-	-
Fitting	-	-	Pad

Notes

COMPRESSOR KIT CONFIGURATIONS

PART NUMBER	COMPRESSOR KIT PART NOS						DESCRIPTION	QTY.
	0513.6112	0515.6112	0516.6112	0593.6112	0595.6112	0596.6112		
0381.0412	●						TM13 Ear Mount 8PV SL 123 12V H 3/4 x 7/8 Bolt	1
0381.0032		●					TM15 Ear Mount 8PV SL 123 12V H 3/4 x 7/8 Bolt	1
0381.0512			●				TM16 Ear Mount 8PV SL 123 12V H 3/4 x 7/8 Bolt	1
0391.0412				●			QP13 Ear Mount 8PV SL 123 12V H 3/4 x 7/8 Bolt	1
0391.0032					●		QP15 Ear Mount 8PV SL 123 12V H 3/4 x 7/8 Bolt	1
0391.0512						●	QP16 Ear Mount 8PV SL 123 12V H 3/4 x 7/8 Bolt	1

● = Additional parts to standard kits.

PARTS VIEW

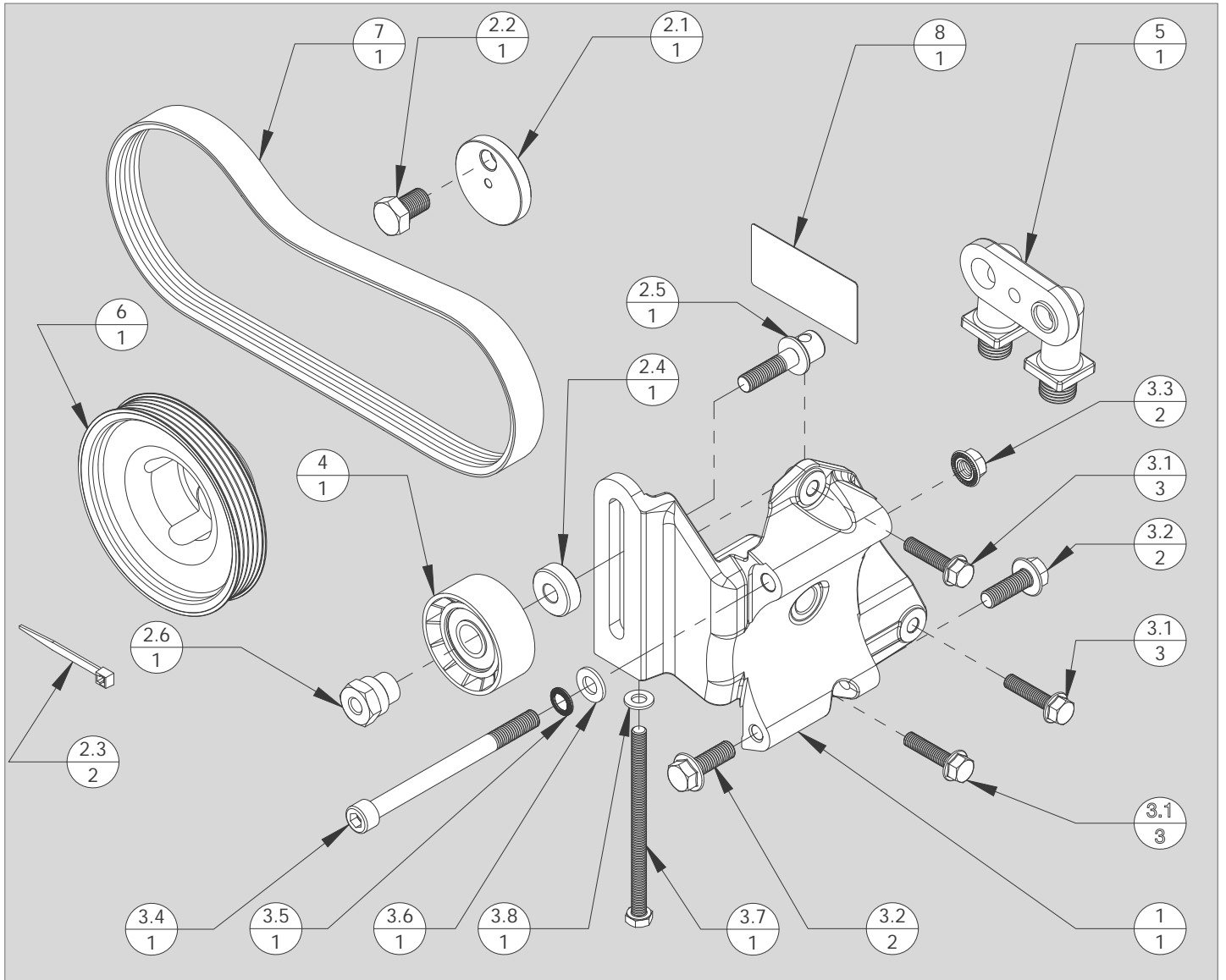

Notes

ITEM	PART NO.	DESCRIPTION	QTY.	COMMENTS
1	0440.2243	Compressor Mount Bracket Assembly	1	-
2	0291.0012	Sub Pack	1	Not Shown
2.1	2803.3773	Crankshaft Pulley Drilling Jig	1	-
2.2	2723.0041	Bolt 1/2 x 0.75 - 20 UNF	1	-
2.3	2763.0051	Cable Tie 5 x 370 - Black	2	-
2.4	2803.2853	Idle Pulley Spacer - 28OD x 10.5ID x 10	1	-
2.5	1703.0153	Idle Pulley Eye Bolt	1	-
2.6	1710.0073	Idle Pulley Nut	1	-
3	0290.3372	Fastener Pack	1	-
3.1	2704.0481	Hex flange bolt Durlok - M8 x 35 : 1.25 - 12.9	3	-
3.2	2705.0491	Hex flange bolt Durlok - M10 x 30 : 1.50 - 12.9	2	-
3.3	2735.0071	Durlok Hexagon Flange Nut - M10 : 1.50	2	-
3.4	2705.0301	Hex socket head cap screw M10 x 130 : 1.50 - 12.9	1	-
3.5	2809.0101	M10 Schnorr safety washer type 'S'	1	-
3.6	2809.0011	Washer M10 Flat DIN 125 - A 10.5	1	-
3.7	2719.0261	Setscrew - M8 X 120 Hex 1.25 8.8	1	-
3.8	2808.0011	Washer M8 Flat DIN 125 - A 8.4	1	-
4	1700.0341	Idle Pulley 60.2 X 21.5	1	-
5	0425.0251	Manifold Inverted - 3/4 x 7/8 Insert O-ring	1	-
6	1701.5043	Crankshaft Drive Pulley	1	-
7	0820.5171	Belt - Poly Groove 4PK 0975	1	-
8	2902.6122	Belt Label - 0500.6122	1	-
9	2901.6122	Installation Instructions - 0500.6112	1	Not Shown

FOREWORD





- The purpose of this manual is to facilitate the installation of a direct drive compressor. The information given is merely instructive, should any complications arise contact the Technical department. The manufacturer's warranty does not cover any problems caused by defective installation or alterations made unless authorised. The manufacturer shall not be responsible for any injury, damage or loss caused directly or indirectly as a result of using this manual or the information contained within it.

<p>1 SAFETY MEASURES:</p> <p>Before fitting the Compressor adapter drive kit, ensure the following for damage:</p> <ul style="list-style-type: none"> a Inner and outer trim and body work b Engine idle pace c Check all the vehicle functions <p>Check list:</p> <ul style="list-style-type: none"> a Ensure that the right kit has been selected b Before installing, check that all the correct pieces are present; also ensure that there are no missing or broken pieces c When fitting, make sure the vehicle is properly protected against damage. 	<p>Installation apparatus</p> <ul style="list-style-type: none"> a Calibrated torque wrench b Hand service tools c Protective covers and shields <p>2 PRECAUTIONS</p> <ul style="list-style-type: none"> a Detach the battery negative lead. b Torque all bolts where stated using a calibrated torque wrench. c Take extreme care with moving parts. d Remove the vehicles ignition key and keep it with you. e Wear safeguards to make sure that liquid refrigerant never touches your skin
---	---

Caution: Measures must be followed accurately to steer clear of the possibility of damage to individuals
Warning: This calls awareness to actions which must be pursued to avoid damage to the components.
NB: This calls awareness to make the job easier or gives useful information.

STANDARD FASTENER TORQUE VALUES

- In the absence of specific torque values detailed in this fitting instruction manual, the following chart can be used as a guide to the maximum safe torque for specific size and grade of fastener.

STRENGTH								
	Max Torque		Max Torque		Max Torque		Max Torque	
Dia / Pitch	lb.ft	Nm	lb.ft	Nm	lb.ft	Nm	lb.ft	Nm
M5 x 0.80	2	3	4.5	6	6.5	9	7.5	10
M6 x 1.00	4	5.5	7.5	10	11	15	13	18
M8 x 1.25	10	13	18	25	26	35	33	45
M10 x 1.25	20	27	39	53	57	78	66	90
M10 x 1.50	18	25	37	50	55	73	63	86
M12 x 1.75	33	45	63	85	97	130	111	150
M14 x 2.00	55	75	103	140	151	205	177	240
M16 x 2.00	85	115	159	215	232	315	273	370

PRE-INSTALLATION

N.B Prior to commencing work, please examine the instructions with care. The alphabetical symbols on the diagram relate to written instructions, numerical symbols relate to the parts listing.

1. Disconnect the battery and remove the ignition key from the vehicle.
2. Using a Viscous fan removal tool (not supplied) remove the viscous fan assembly from the engine.
3. Using a suitable tool rotate the automatic belt tensioner to release the tension and remove the original manufacturers drive belt (A) taking care to check the direction of rotation and noting the original routing, if different from the diagram shown in Fig.11 report your findings to your Kit/System supplier before proceeding - Fig 1

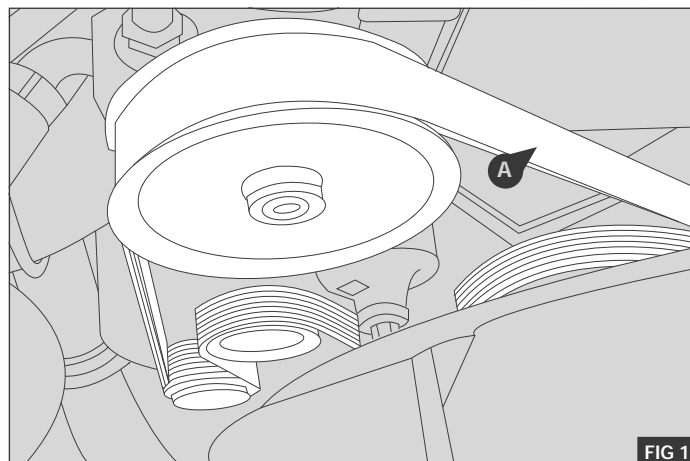

Warning: To avoid damage to the engine dual mass flywheel the subsequent method must be performed correctly.

4. Temporarily move the cable (B) to gain access to the starter motor bolt (C) - Fig 2
5. Temporarily remove the two bolts (C) that fasten the starter motor (D) to the engine - Fig 2
6. Move the starter motor (D) to gain access to the flywheel ring gear.
7. Using a suitable tool lock the engine ring gear at point (E) - Fig 3
8. Remove the three bolts retaining the engine crankshaft damper and carefully remove the damper.
9. Remove the original manufacturers loom (F) from the two mounting holes (G) located on the near side of the engine block and tie back in a suitable location - Fig 6

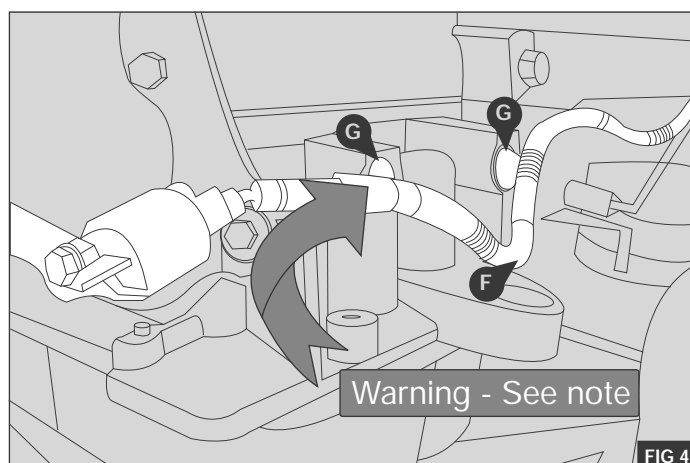
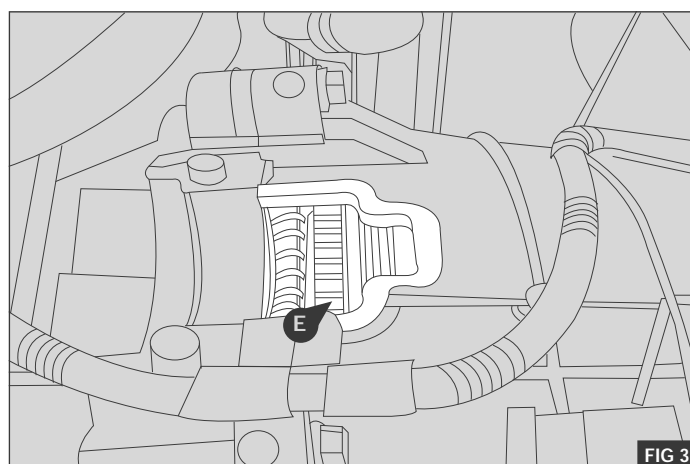
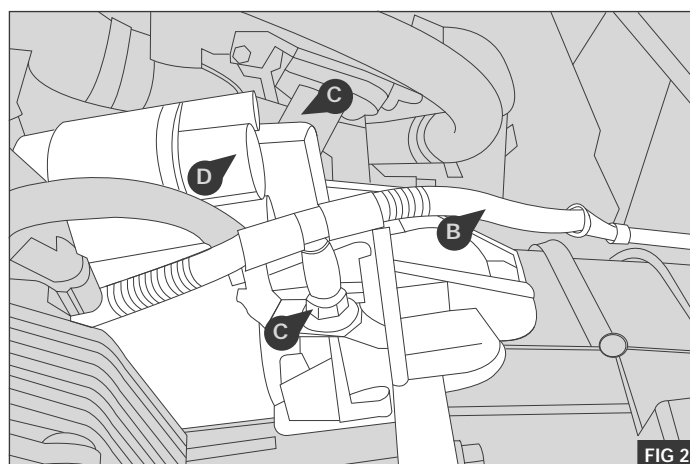

DRIVE PULLEY INSTALLATION

1. Mount the drilling jig (2.1) to the rear of the previously removed engine damper (H) fixing it with bolt (2.2) - Fig 5

Warning: Centralise the drilling jig (2.1) between the locating lugs on the damper.

2. Drill a 5mm hole through the drilling jig and crankshaft damper (H)
3. Assemble the supplied crankshaft pulley (6) and the original crankshaft damper (H) and fix to the original position using the original bolts (J) - Fig 6
4. Lock the starter ring and tighten the bolts (J) in the following sequence. See Fig 7:

First Stage - Torque all three bolts to 45 Nm, using a calibrated torque wrench.

Second Stage - Tighten to 120 Degrees using a torque angle gauge.

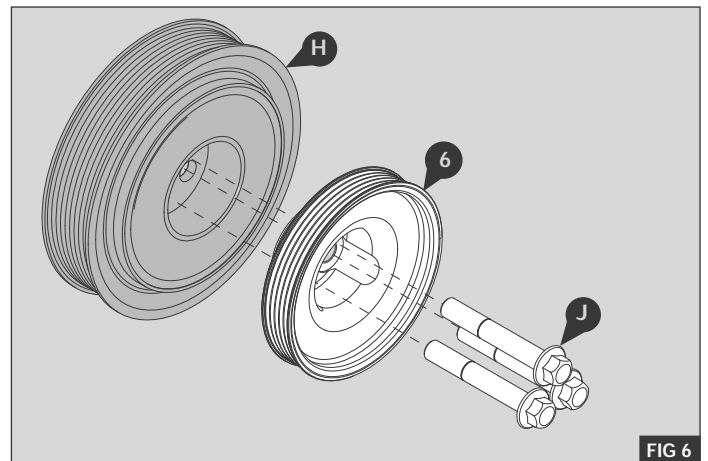
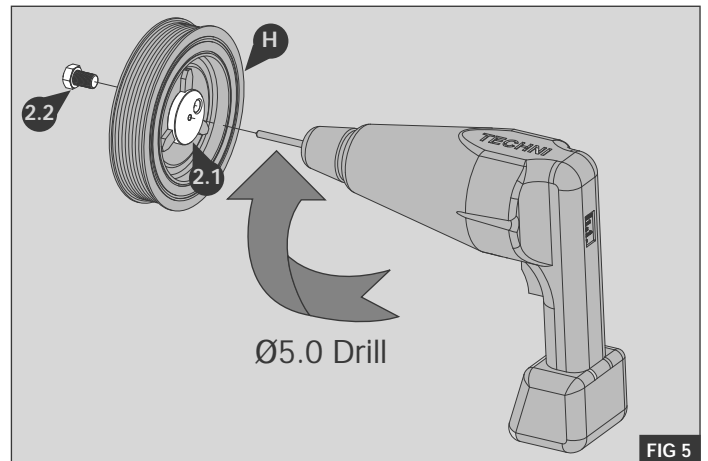

Warning: Bolts are to be used 3 times only, each time they are removed they are to be centre punched to show they have been used.

5. Reinstall the viscous fan assembly previously removed and tighten using a viscous fan wrench
6. Reinstall the starter motor and cable previously removed.
7. Torque the starter motor bolts (C) to 25 Nm

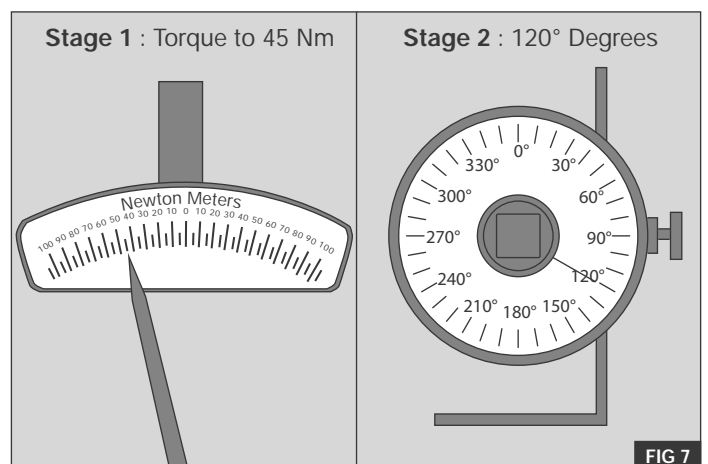

TENSIONER INSTALLATION

1. Assemble the idle pulley assembly as detailed, do not fully tighten the nut (2.6) or M8 x 120 bolt (3.7) - Fig 8

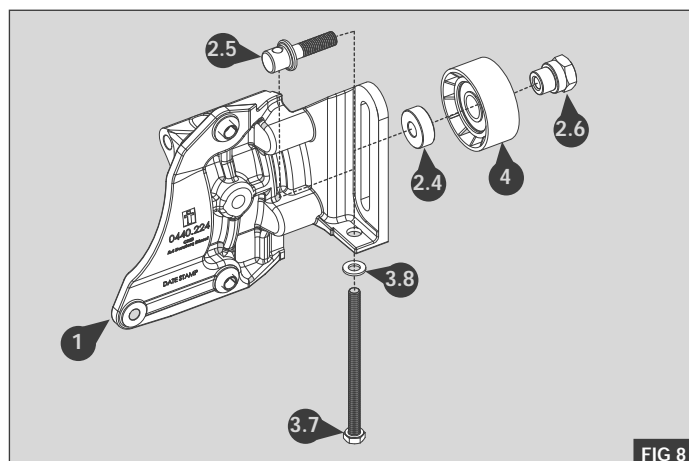

FIG 8

MOUNT BRACKET INSTALLATION

1. Install the compressor mount bracket (1) to the engine block using bolts (3.1) - Fig 9
2. Torque M8 x 30 bolts (3.1) to 25 Nm

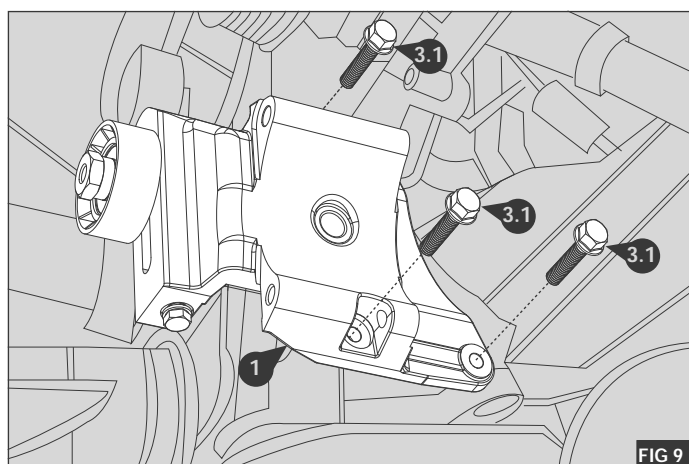

FIG 9

COMPRESSOR INSTALLATION

1. Remove the compressor manifold and fit the supplied inverted manifold (5) to the compressor - Fig 10
2. Fit the compressor to the previously fitted mount bracket assembly (1) using bolt (3.4) with Schnorr safety washer (3.5) and flat washer (3.6) and Dulok nut (3.3) then secure with bolts (3.2) - Fig 11
3. Torque bolts (3.2) and (3.4) to 50Nm using a calibrated torque wrench.

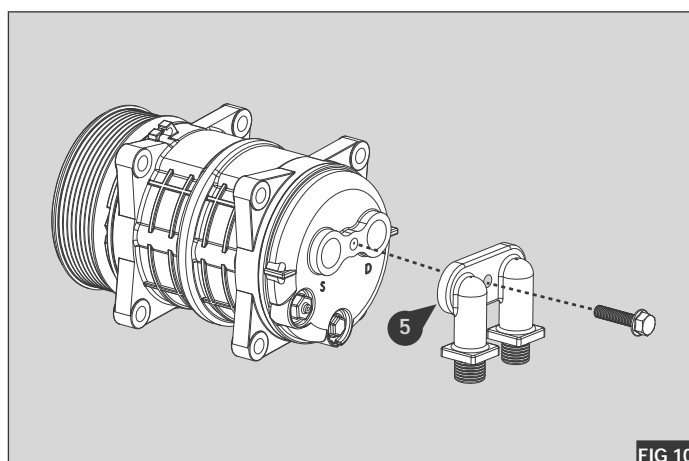

FIG 10

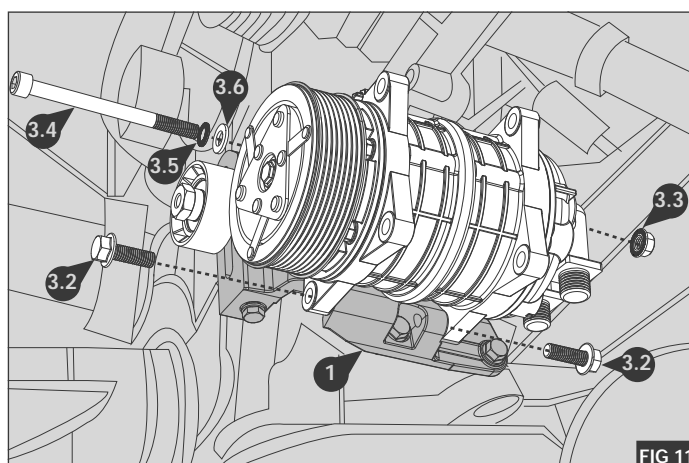



FIG 11

DRIVE BELTS

1. Refit the original manufacturers drive belt  previously removed to the engine in the same configuration and in accordance with the original manufacturers design detailed in - Fig 12

CP Crankshaft pulley damper

AT Automatic belt tensioner

AL Alternator

PS Power steering pump

IP Idle pulley

VP Vacuum pump

WP Water pump

2. Install the supplied compressor drive belt  as detailed in - Fig 13

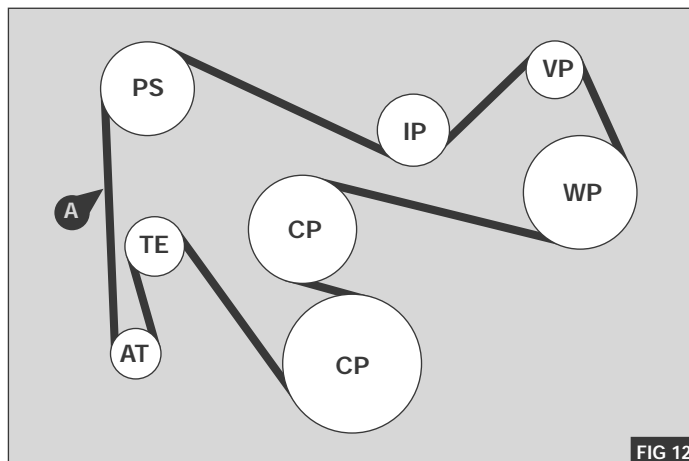

FIG 12

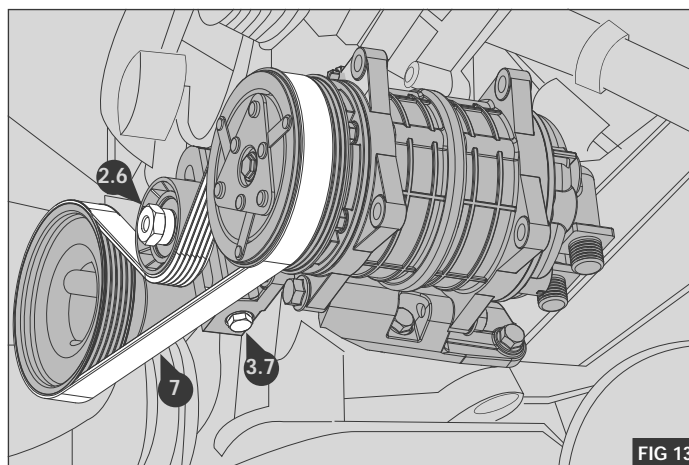





FIG 13

NB: Where applicable and dependent on, the compressor model, align the supplied drive belt by installing in the correct clutch groove - Fig.14 Seltec PV8 has the same gauge line (46.55) as the Sanden PV6 & PV7, belt is fitted to front groove.

Sanden PV8 has a unique gauge line (50.11) in most cases, belt is fitted to second groove. If in any doubt, please check with your compressor supplier

3. Tension the compressor drive belt (see table below) by tightening the draw bolt 
4. Once the correct tension has been attained, lock the idle pulley assembly with nut  - Fig 13
5. Torque nut  to 30 Nm

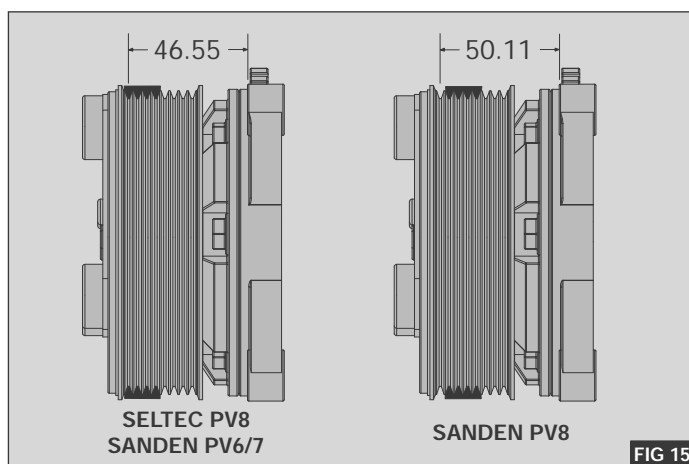





FIG 15

Belt Tension Table	
Belt Life	Belt Tension
New Belt	55 - 65 kg
Used Belt	40 - 45 kg

POST INSTALLATION

1. Unclip the plastic clip  from the radiator hose  - Fig 16
2. Move the radiator hose  80 mm in the direction shown to allow for clearance against the compressor assembly.
3. Re attach the clip  with the hose in the new position - Fig 15

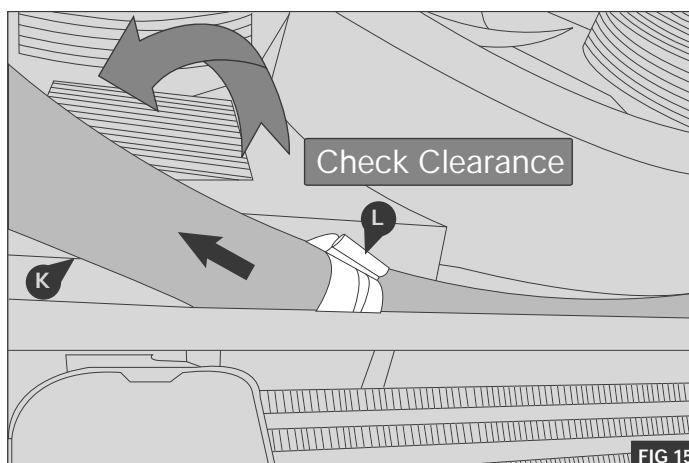

FIG 15

POST INSTALLATION - CONTINUED

4. Attach the radiator hose (K) to the intercooler hose (M) using the supplied cable ties (2.3) - Fig 16

Warning: Ensure that there is clearance between the radiator hose and the compressor assembly of at least 30 mm - Fig 16

5. Before starting the engine check all the installed parts and ensure that the belt is installed correctly. Run the unit for at least ten minutes, then check the whole mounting assembly and previously removed parts. Attach the supplied warning label (8) on to a suitable location.

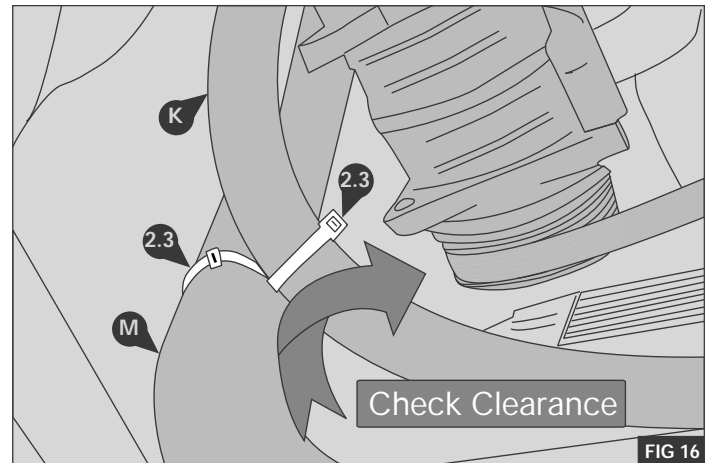

Note